

For additional information, see the accompanying data sheet for this transducer.

Ordering Information

MANUAL OVERRIDE		RANGE	
311	Without override	315	3 - 15 psig
313	With override	020	0 to 20 psig

Dimensions

(mm)

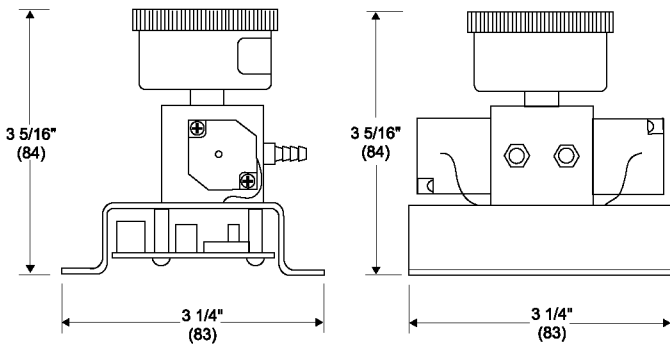
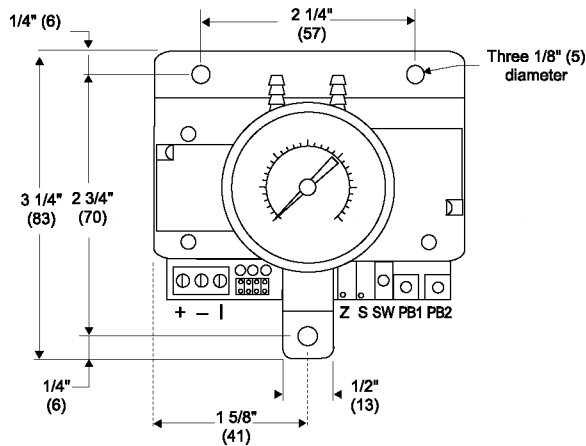
Figure 1. Electropneumatic Transducer Dimensions

Specifications
Accuracy*: ± 1% FS

Maximum Supply Pressure: 40
PSI

Pressure Differential: 0.1 PSI
(supply to branch)

Supply Voltage: 18 - 28 VAC/
VDC

Supply Current: 150 mA

Enclosure: 18 gage C.R. steel chassis

Finish: Baked-on enamel PMS2GR88B

Conformance: EMC Standards EN50082-1(1992), EN55014(1993)/
EN60730-1(1992)

Compensated Temperature Range
25°F to 150°F (4°C to 65°C)

T. C. Error: ± 0.025%/°F (.03%/°C)

Media Compatibility: Clean dry air or any inert gas

Port Connection: 1/4-inch outer diameter poly tubing

Environmental: 10 to 90% RH non-condensing

Termination: Screw terminal block

Wire Size: 12 gage maximum

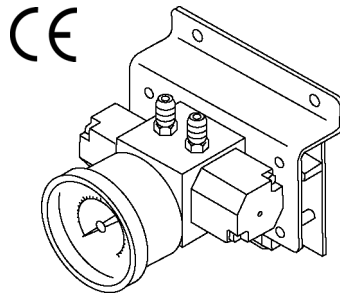
Input Impedance: 301 ohms (4 - 20 mA); 10,000 ohms (0 - 5 or 0 - 10
VDC)

Figure 2. Electropneumatic Transducer

Weight: 1.0 lb. (.45 kg)

** Includes nonlinearity, hysteresis, and non-repeatability.*
Installation
Inspection

Inspect the transducer packaging for signs of damage. If damaged, notify the carrier immediately.

Requirements

- Tools (not provided):
 - Digital volt-ohm meter (DVM)
 - Appropriate screwdriver for mounting screws
 - Appropriate drill and drill bit for mounting screws
- Appropriate accessories
- Three #8 self-tapping mounting screws (not provided)
- Training: Installer must be a qualified and experienced technician

WARNING !

- Do not use on oxygen service, in an explosive or hazardous environment, or with flammable or combustible material.
- Disconnect the power supply before installing the transducer. Failure to do so can result in electrical shock and equipment damage.
- Make all connections in accordance with the job wiring diagram and national and local electrical codes. Use only copper conductors.
- Use electrostatic discharge precautions such as wrist straps when installing and wiring the transducer.
- Do not exceed ratings for the transducer.

Mounting

The electropneumatic transducer must be mounted in an upright position so that the ports are facing upwards and the gage can be read easily.

- Select the mounting location.
- Mount the transducer on a vertical surface with three #8 self-tapping screws (not provided).
- Pull wires through the bottom of the transducer and make the necessary connections.
- Make the pneumatic connections.

Wiring

Use 12 AWG wire maximum for wiring terminals and flexible 1/4-inch outer diameter poly tubing for main and branch pneumatic connections. See Figures 3 and 4 for wiring configurations and Figures 5 through 7 for jumper designations.

CAUTION !

- Ensure that the main supply pressure does not exceed 40 PSI.
- Ensure a minimum of 6 to 10 feet (1.8 to 3.0 m) of tubing between the transducer and the actuator.
- For a 24 VAC supply voltage, ensure that the hot and neutral are not reversed. If more than one transducer is being powered from the same transformer, the hot and neutral should be the same for each transducer.

Note: The transducer's gage is for indication only. The transducer measures more precisely than what is displayed on the gage.

Typical Applications (wiring diagrams)

Figures 3 and 4 illustrate typical wiring diagrams for the electropneumatic transducer.

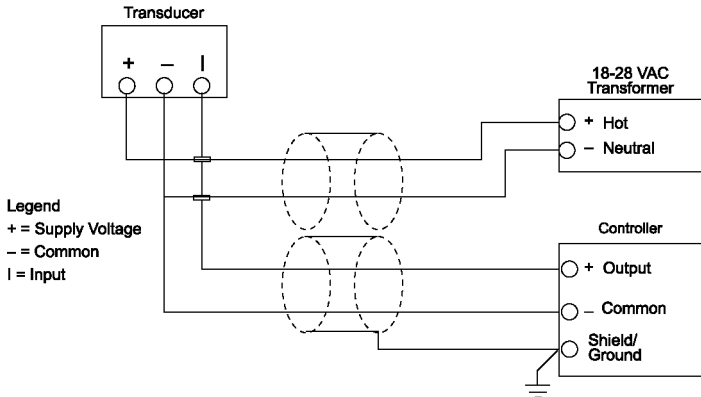

Figure 3. Wiring the Electropneumatic Transducer With a 24 VAC Supply

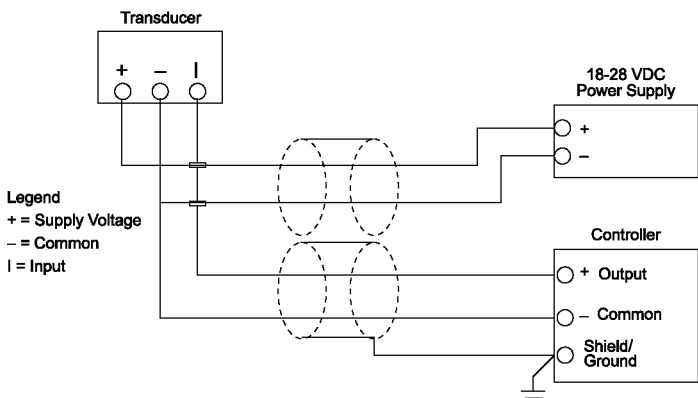

Figure 4. Wiring the Electropneumatic Transducer With a 24 VDC Supply

CAUTION!

- This transducer contains a half-wave rectifier power supply and must not be powered from transformers powering other devices with non-isolated full-wave rectifier power supplies.

Adjustments

Jumper Configuration

The electropneumatic transducer is factory configured for 4 - 20 mA output. To change the input configuration, adjust the jumper settings. See Figures 5, 6, and 7.

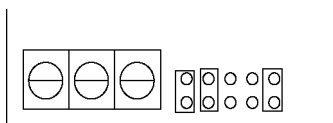

Figure 5. Jumper Settings for Electropneumatic Transducers With 4 - 20 mA Input

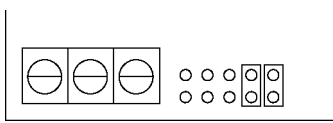

Figure 6. Jumper Settings for Electropneumatic Transducers With 0 - 5 VDC Input

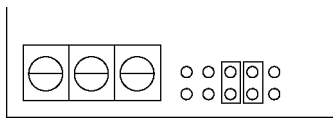

Figure 7. Jumper Settings for Electropneumatic Transducers With 0 - 10 VDC Input

Checkout

1. Verify that the transducer is mounted in the correct position.
2. Verify the appropriate input signal and supply voltage.
3. Verify the appropriate input configuration.

CAUTION!

- Do not connect 120 VAC to the electropneumatic transducer.

Transducer Operation

1. Adjust the input signal to obtain a maximum output pressure for the appropriate range.
2. Ensure that the output is 15 or 20 PSI.
3. Adjust the input signal to obtain a minimum output pressure.
4. Ensure that the output is 0 or 3 PSI.

Calibration

All electropneumatic transducers are factory calibrated to meet or exceed published specifications. If field adjustment is necessary, follow these instructions:

1. Connect air to the Main port. See Figure 8.
2. Connect an accurate gage to the Branch port using a minimum of 6 to 10 feet (1.8 to 3.0 m) of tubing.
3. Connect the [+] and [-] terminals to an appropriate power source for the transducer. The transducer can accept either a 24 VAC or VDC supply voltage. The maximum supply voltage should not exceed 30 VAC/VDC.
4. Apply a low input signal to the [-] and [I] terminals (0 VDC or 4 mA).
5. Adjust [Z] to obtain the desired low output pressure.
6. Apply a high input signal to the [-] and [I] terminals (5/10 VDC or 20 mA).
7. Adjust [S] to obtain the desired high output pressure.
8. Repeat steps 4 through 7 until the transducer is fully calibrated.

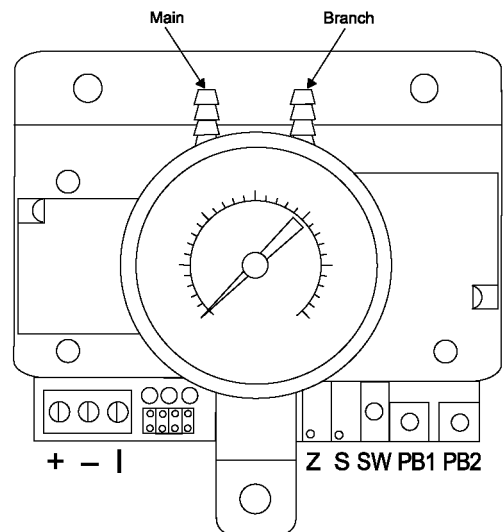

- + = Supply Voltage
- = Common
- I = Input
- Z = Zero
- S = Span
- SW = Up (Manual) Down (Auto)
- PB1 = Increase
- PB2 = Decrease

Figure 8. Terminal Locations on the Electropneumatic Transducer

Maintenance

Perform regular maintenance on the total system to ensure the sustained optimum performance of the electropneumatic transducer.

Field Repair

Do not attempt to repair the electropneumatic transducer. Replace a malfunctioning transducer with a functional transducer if necessary.

Warranty

See the accompanying data sheet for additional information. For technical / application assistance, call your nearest office.

EUROPE
Baird House, Units 6 & 7 Dudley Innovation Centre Pensnett Estate • Kingswinford West Midlands • DY6 8XZ United Kingdom 01384-271113 • Fax 01384-271114

AUSTRALIA
4 Armiger Court, Unit 2 Holden Hill • S.A. 5088 Australia 08-8359-4333 • Fax 08-8395-4433

ASIA
No. 22 Lorong 21A Geylang #11-02 Chin Hin Hang Building Singapore • 388431 65-6392-7273 • Fax 65-6392-7276

CANADA
155 McIntosh Drive, Unit 5 Markham • Ontario • L3R 0N6 Canada 905-474-9215 • Fax 905-474-0876